

Homework Assignment No. 11 - Solutions

1.) **18.8**

$$A_V = \frac{A}{1 + A\beta} \quad | \quad \text{From Chapter 12, } GE = \frac{1}{1 + A\beta} \approx \frac{1}{A\beta}$$

$$\frac{1}{\beta} = 200 \quad | \quad GE \approx \frac{200}{A} \leq 0.002 \rightarrow A \geq \frac{200}{0.002} = 10^5 \quad | \quad A \geq 100 \text{ dB}$$

2.) **18.10**

(a) Series-shunt (b) Shunt-series (c) Series-series (d) Shunt-shunt

3.) **18.15** (a)

$$h_{11}^A = \left. \frac{\mathbf{v}_1}{\mathbf{i}_1} \right|_{\mathbf{v}_2=0} = 15\text{k}\Omega \quad | \quad h_{11}^F = 4.3\text{k}\Omega \parallel 39\text{k}\Omega = 3.87\text{k}\Omega \quad | \quad h_{11}^T = 18.9\text{k}\Omega$$

$$h_{22}^A = \left. \frac{\mathbf{i}_2}{\mathbf{v}_2} \right|_{\mathbf{i}_1=0} = (1\text{k}\Omega)^{-1} = (1\text{k}\Omega)^{-1} \quad | \quad h_{22}^F = (39\text{k}\Omega + 4.3\text{k}\Omega)^{-1} = (43.3\text{k}\Omega)^{-1} \quad | \quad h_{22}^T = 1.02\text{mS}$$

$$h_{21}^A = \left. \frac{\mathbf{i}_2}{\mathbf{i}_1} \right|_{\mathbf{v}_2=0} = -\frac{15\text{k}\Omega(5000)}{1\text{k}\Omega} = -75,000 \quad | \quad h_{21}^F = \left. \frac{\mathbf{i}_2}{\mathbf{i}_1} \right|_{\mathbf{v}_2=0} = -\frac{4.3\text{k}\Omega}{39\text{k}\Omega + 4.3\text{k}\Omega} = -0.0993$$

$$h_{12}^A = \left. \frac{\mathbf{v}_1}{\mathbf{v}_2} \right|_{\mathbf{i}_1=0} = 0 \quad | \quad h_{12}^F = \left. \frac{\mathbf{v}_1}{\mathbf{v}_2} \right|_{\mathbf{i}_1=0} = \frac{4.3\text{k}\Omega}{39\text{k}\Omega + 4.3\text{k}\Omega} = 0.0993$$

(b) $A = \frac{-h_{21}^A}{(R_S + h_{11}^T)(h_{22}^T + G_L)} = \frac{-(-75000)}{(1\text{k}\Omega + 15\text{k}\Omega + 3.87\text{k}\Omega)\left(\frac{1}{5.6\text{k}\Omega} + \frac{1}{1\text{k}\Omega} + \frac{1}{43.3\text{k}\Omega}\right)} = 3140$

$\beta = 0.0993$

(c) $A_V = \frac{3140}{1 + 3140(0.0993)} = 10.0 \quad | \quad h_{21}^A \gg h_{21}^F \quad | \quad h_{12}^F \gg h_{12}^A \quad | \quad (R_{IN} = 6.22 \text{ M}\Omega, R_{OUT} = 2.66 \Omega)$

4.) **18.17**

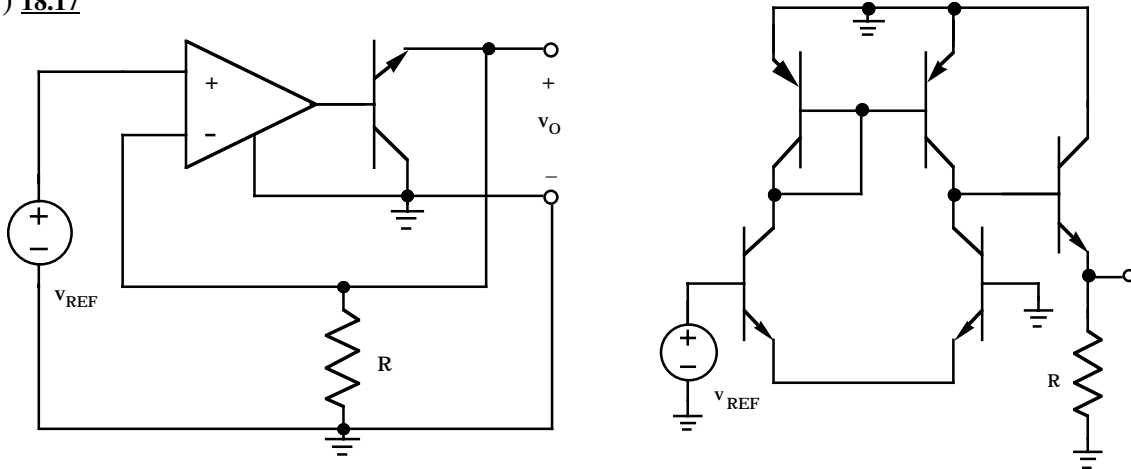

$$h_{11}^F = \left. \frac{\mathbf{v}_1}{\mathbf{i}_1} \right|_{\mathbf{v}_2=0} = 0 \quad | \quad h_{22}^F = \left. \frac{\mathbf{i}_2}{\mathbf{v}_2} \right|_{\mathbf{i}_1=0} = \frac{1}{R} \quad | \quad h_{12}^F = \left. \frac{\mathbf{v}_1}{\mathbf{v}_2} \right|_{\mathbf{i}_2=0} = 1$$

$$A = g_{m1} \left(r_{o1} \parallel r_{o4} \parallel \left[r_{\pi 5} + (\beta_o + 1)R \right] \right) \frac{(\beta_o + 1)R}{r_{\pi 5} + (\beta_o + 1)R} = g_{m1} \frac{r_{o1} \parallel r_{o4}}{(r_{o1} \parallel r_{o4}) + r_{\pi 5} + (\beta_o + 1)R} (\beta_o + 1)R$$

4.) Continued

$$r_{o1} = \frac{50 + 1.4}{10^{-4}} = 514\text{k}\Omega \quad | \quad r_{o4} = \frac{50 + 11.3}{10^{-4}} = 613\text{k}\Omega \quad | \quad r_{o1} \parallel r_{o4} = 280\text{k}\Omega$$

$$I_{C5} = \frac{12}{10^4} = 1.2\text{mA} \quad | \quad r_{\pi5} = \frac{100(0.025)}{1.2\text{mA}} = 2.08\text{k}\Omega$$

$$A = 40(10^{-4})(280\text{k}\Omega) \frac{(101)10\text{k}\Omega}{280\text{k}\Omega + 2.08\text{k}\Omega + (101)10\text{k}\Omega} = 876$$

$$A_V = \frac{A}{1 + T} = \frac{876}{1 + 876(1)} = \frac{109}{110} = 0.999$$

$$R_{IN} = R_{ID}(1 + T) = 2r_{\pi1}(1 + T) = 2 \frac{100(0.025)}{10^{-4}}(877) = 43.9 \text{ M}\Omega$$

$$R_{OUT} = \frac{R \parallel \frac{r_{\pi5} + r_{o2} \parallel r_{o4}}{\beta_o + 1}}{1 + T} = \frac{10\text{k}\Omega \parallel \frac{2.08\text{k}\Omega + 280\text{k}\Omega}{101}}{877} = 2.49 \Omega$$

$$\mathbf{i}_o = \alpha_o \mathbf{i}_e = \alpha_o \frac{\mathbf{v}_o}{R} \quad | \quad \frac{\mathbf{i}_o}{\mathbf{v}_{ref}} = \frac{\alpha_o}{R} \frac{\mathbf{v}_o}{\mathbf{v}_{ref}} = \frac{100}{101} \left(\frac{1}{10^4} \right) (0.999) = 98.9 \mu\text{S}$$

5.) A series-shunt feedback amplifier is shown. Use the methods of feedback analysis to find the numerical values of v_2/v_1 , v_1/i_1 , and v_2/i_2 . Assume that all transistors are matched and that $g_m = 1\text{mS}$ and $r_{ds} = \infty$.

Solution

(This problem has been re-assigned in Homework 12)

