

Homework Assignment No. 8 - Solutions**Problem 15.10 (15.9) of the text.**Note that the dc equivalent circuits are identical for Q₁ and Q₂.

$$V_{EQ} = \frac{180k\Omega}{180k\Omega + 300k\Omega} 15V = 5.63V \quad | \quad R_{EQ} = 180k\Omega || 300k\Omega = 113k\Omega$$

$$I_B = \frac{5.63 - 0.7}{113 + 101(20)} \frac{V}{k\Omega} = 2.31\mu A \quad | \quad I_C = 100I_{B1} = 232\mu A \quad | \quad I_E = 101I_{B1} = 234\mu A$$

$$V_{CE} = 15 - 2 \times 10^4 I_E - 2 \times 10^4 I_C = 5.71V$$

$$r_{\pi} = \frac{100(0.025V)}{232\mu A} = 10.8k\Omega \quad | \quad r_o = \frac{(70 + 5.71)V}{232\mu A} = 326k\Omega$$

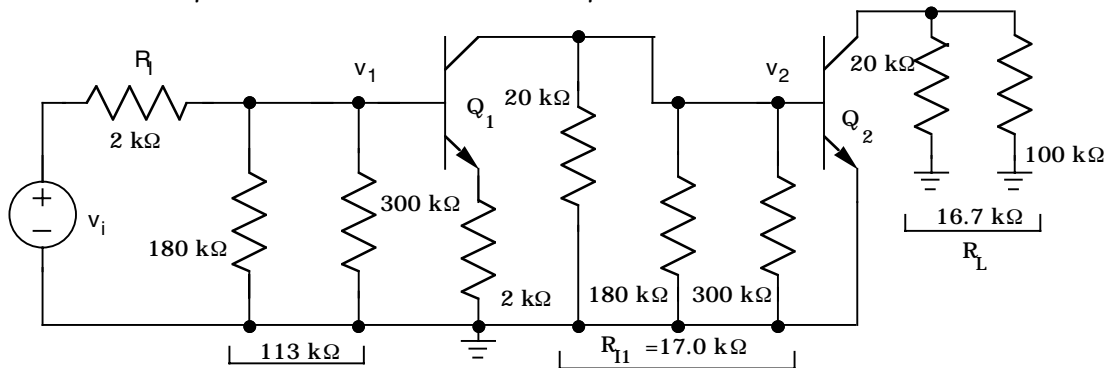

$$A_v = \left(\frac{R_{in}}{2k\Omega + R_{in}} \right) A_{v1} A_{v2}$$

$$A_{v1} = \frac{v_2}{v_1} = - \frac{\beta_{o1}(R_{I1} || r_{\pi 2})}{r_{\pi 1} + (\beta_{o1} + 1)R_5} = - \frac{100(17k\Omega || 10.8k\Omega)}{10.8k\Omega + (101)2k\Omega} = -3.10$$

$$A_{v2} = \frac{v_o}{v_2} = -g_{m2}R_L \quad | \quad R_L = 100k\Omega || 20k\Omega = 16.7k\Omega \quad | \quad A_{v2} = -40(232\mu A)(16.7k\Omega) = -155$$

$$R_{in} = R_{B1} || (r_{\pi 1} + (\beta_{o1} + 1)R_5) = 300k\Omega || 180k\Omega || [10.8k\Omega + (101)2k\Omega] = 73.6k\Omega$$

$$A_v = \left(\frac{73.6k\Omega}{2k\Omega + 73.6k\Omega} \right) (-3.10)(-155) = +468 \quad | \quad R_{out} = 20k\Omega || r_{o2} = 20k\Omega || 326k\Omega = 18.8k\Omega$$

Problem 15.17 (15.14 careful, second edition has parts b and c) of the text.

$$I_{C1} = 80 \frac{0.7 - (-9)}{100 + 81(24)} \frac{V}{k\Omega} = 325\mu A \quad | \quad V_{EQ2} = 9 - 9100I_{C1} = 6.04V \quad | \quad R_{EQ2} = 9.1k\Omega$$

$$I_{C2} = 80 \frac{9 - 0.7 - 6.04}{9.1 + 81(12)} \frac{V}{k\Omega} = 184\mu A \quad | \quad V_{C1} = 9 - 9.1k\Omega(I_{C1} - I_{B2}) = 6.06V$$

$$V_{E1} = -9 + I_{E1}(24k\Omega) = -1.10V \quad | \quad V_{CE1} = 6.06 - (-1.10) = 7.16V$$

$$V_{C2} = -9 + I_{C2}(43k\Omega) = -1.09V \quad | \quad V_{E2} = V_{C1} + 0.7 = 6.76V \quad | \quad V_{EC2} = 7.85V$$

$$Q_1 : (325\mu A, 7.16V) \quad Q_2 : (184\mu A, 7.85V)$$

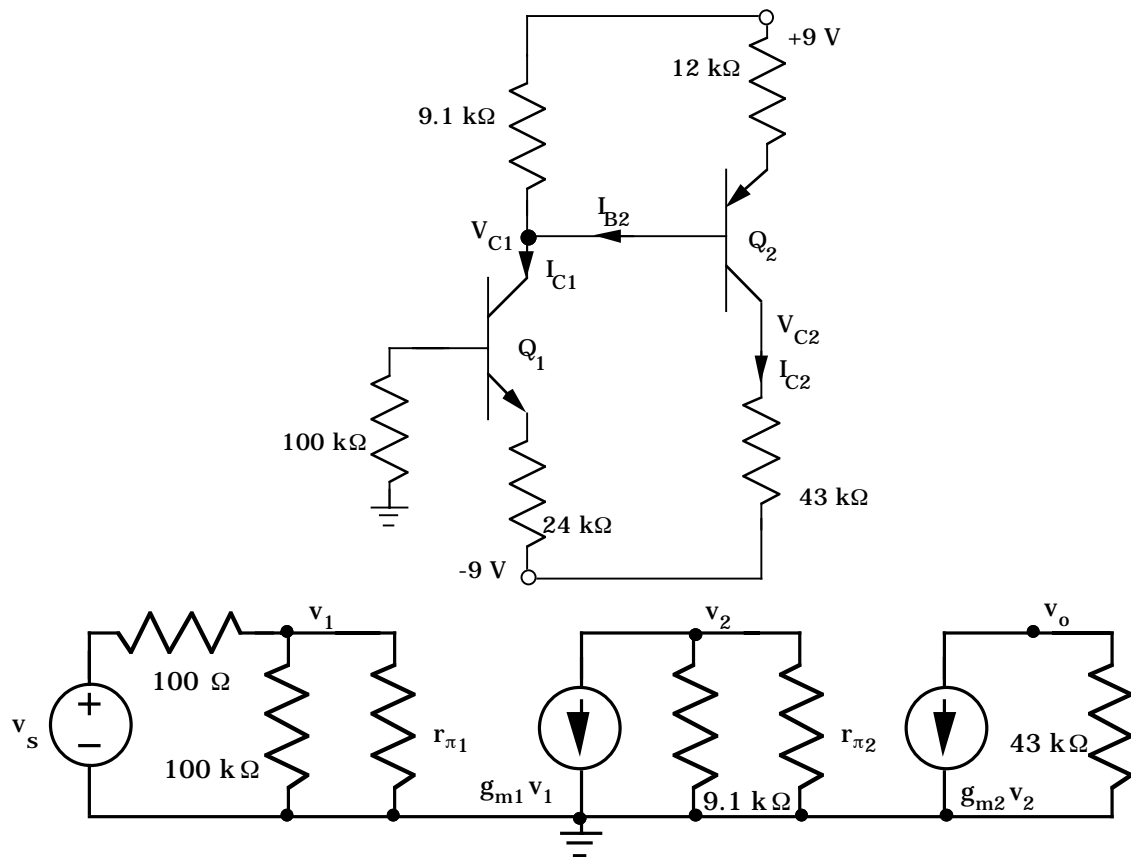
Problem 15.17 - Continued

$$g_{m1} = 40(325\mu A) = 13.0\text{mS} \quad | \quad r_{\pi1} = \frac{80}{13.0\text{mS}} = 6.15\text{k}\Omega$$

$$g_{m2} = 40(184\mu A) = 7.36\text{mS} \quad | \quad r_{\pi2} = \frac{80}{7.36\text{mS}} = 10.9\text{k}\Omega$$

$$R_{in} = 100\text{k}\Omega \parallel r_{\pi1} = 100\text{k}\Omega \parallel 6.15\text{k}\Omega = 5.79\text{k}\Omega$$

$$v_o = -g_{m2}R_{C2}v_2 = -(7.36\text{mS})(43\text{k}\Omega)v_2 = -317v_2$$

$$v_2 = -g_{m1}(R_{C1} \parallel r_{\pi2}) \left(\frac{R_{in}}{100\Omega + R_{in}} \right) v_s = -13.0\text{mS}(9.1\text{k}\Omega \parallel 10.9\text{k}\Omega) \left(\frac{5.79\text{k}\Omega}{100\Omega + 5.79\text{k}\Omega} \right) = -63.4v_s$$

$$A_v = \frac{v_o}{v_s} = -317(-63.4) = +2.01 \times 10^4 \quad \text{or} \quad 86.1\text{ dB}$$

Problem 15.20 (15.17) of the text.

dc equivalent circuit:

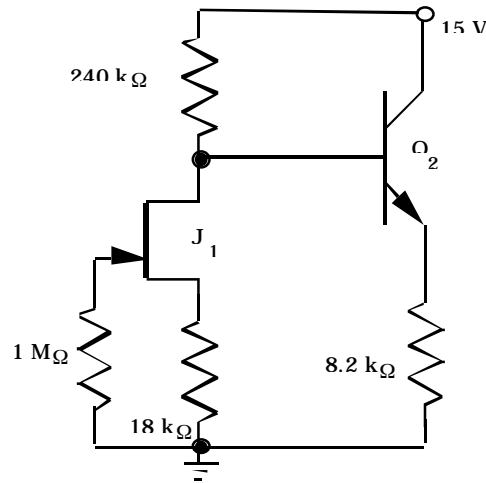

We assume active region operation for \$J_1\$ and \$Q_2\$.

$$I_{D1} = I_{DSS} \left(1 - \frac{V_{GS1}}{V_P} \right)^2 \quad | \quad I_{D1} = 0.005 \left(1 - \frac{-18000 I_{D1}}{-1} \right)^2 \rightarrow I_{D1} = 50\mu\text{A}$$

$$V_{EQ2} = 15 - I_{D1}(240\text{k}\Omega) = 3.00\text{V} \quad | \quad R_{EQ2} = 240\text{k}\Omega \quad | \quad I_{C2} = 100 \frac{3 - 0.7}{240 + 101(8.2)} \frac{\text{V}}{\text{k}\Omega} = 215\mu\text{A}$$

$$V_{CE2} = 15 - 8200 I_{E2} = 13.2\text{V} \quad | \quad \text{Checking } V_{DS1}: V_{D1} = 15 - (50 + 2.15)(\mu\text{A})(240\text{k}\Omega) = 2.48\text{V}$$

$$V_{DS1} = 2.48 - (50\mu\text{A})(18\text{k}\Omega) = 1.58\text{V} \quad | \quad V_{GS1} - V_P = -(50\mu\text{A})(18\text{k}\Omega) + 1 = 0.1\text{V} \rightarrow J_1 \text{ is in pinchoff.}$$

ac equivalent circuit:

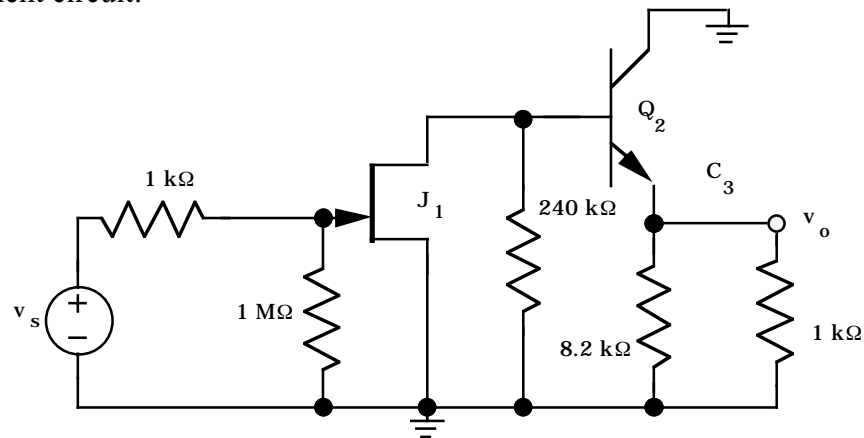

Problem 15.20 - Continued

$$g_{m1} = \frac{2}{|-1|} \sqrt{(5mA)50\mu A} = 1.00mS \quad | \quad r_{\pi 2} = \frac{100(0.025V)}{215\mu A} = 11.6k\Omega$$

$$A_{v1} = \frac{v_1}{v_i} = -\frac{10^6}{10^6 + 10^3} g_{m1} R_{L1} = -\frac{10^6}{10^6 + 10^3} g_{m1} \left[R_{D1} \parallel (r_{\pi 2} + (\beta_{o2} + 1)R_{L2}) \right]$$

$$R_{L2} = R_{E2} \parallel R_L = 8.2k\Omega \parallel 1k\Omega = 891\Omega \quad | \quad A_{v1} = (-1.00mS) \left[240k\Omega \parallel (11.6k\Omega + 101(891\Omega)) \right] = -71.4$$

$$A_{v2} = \frac{v_o}{v_1} = +\frac{101(0.891k\Omega)}{11.6k\Omega + 101(0.891k\Omega)} = 0.886 \quad | \quad A_v = -71.4(0.866) = -63.2 \quad | \quad R_{in} = 1M\Omega$$

$$R_{out} = R_{E2} \parallel \left\| \frac{R_{th2} + r_{\pi 2}}{\beta_{o2} + 1} = 8.2k\Omega \parallel \frac{240k\Omega + 11.6k\Omega}{101} = 8.2k\Omega \parallel 2.49k\Omega = 1.91k\Omega \right.$$

Note : R_{out} and A_v would be lower if r_{o1} were also included.

$$(b) A_{v1} = \frac{v_1}{v_i} = -\frac{10^6}{10^6 + 10^3} \frac{g_{m1} R_{L1}}{1 + g_{m1} R_5}$$

$$A_{v1} = -0.999 \frac{(1.00mS) \left[240k\Omega \parallel (11.6k\Omega + 101(0.891k\Omega)) \right]}{1 + (1.00mS)(18k\Omega)} = -3.75$$

$$A_{v2} = \frac{v_o}{v_1} = +\frac{101(0.891k\Omega)}{11.6k\Omega + 101(0.891k\Omega)} = 0.886 \quad | \quad A_v = -3.75(0.866) = -3.25$$

Problem 15.43 (15.30) of the text.

$$(a) I_C = \alpha_F I_E = \frac{1}{2} \frac{\beta_F}{\beta_F + 1} \frac{12 - V_{BE}}{R_{EE}} = \frac{1}{2} \left(\frac{100}{101} \right) \left(\frac{12 - 0.7}{2.7 \times 10^5} \right) = 20.7 \mu A \quad | \quad V_C = 12 - 3.3 \times 10^5 I_C = 5.17V$$

$$V_{CE} = V_C - (-0.7V) = 5.87V \quad | \quad Q\text{-Point} = (20.7\mu A, 5.87V)$$

$$(b) A_{dd} = -g_m R_C = -40(20.7\mu A)(330k\Omega) = -273$$

$$R_{id} = 2r_{\pi} = 2 \frac{\beta_o V_T}{I_C} = 2 \frac{100(0.025V)}{20.7\mu A} = 243k\Omega \quad | \quad R_{od} = 2R_C = 660k\Omega$$

$$(c) A_{cc} = -\frac{\beta_o R_C}{r_{\pi} + (\beta_o + 1)2R_{EE}} = -\frac{100(330k\Omega)}{122k\Omega + 2(101)270k\Omega} = -0.604$$

$$A_{dd} = -\frac{g_m R_C}{2} = -137 \quad | \quad A_{cd} = A_{cc} \quad | \quad CMRR = \left| \frac{-137}{-0.604} \right| = 227 \quad \text{or } 47.1 \text{ dB (very low)}$$

$$R_{ic} = \frac{r_{\pi} + (\beta_o + 1)2R_{EE}}{2} = \frac{122k\Omega + 2(101)270k\Omega}{2} = 27.3M\Omega$$

Problem 15.71 (15.52 - γ and $2\phi_F$ are given in second edition) of the text.

$$(a) V_{SS} - V_{GS} = 2I_{DSS}R_{SS} \quad | \quad V_{GS} = V_{TN} + \sqrt{\frac{2I_D}{K_n}} \quad | \quad V_{SS} = 2I_{DSS}R_{SS} + V_{TN} + \sqrt{\frac{2I_D}{K_n}}$$

$$V_{TN} = V_{TO} + \gamma(\sqrt{V_{SB} + 0.6} - \sqrt{0.6}) = V_{TO} + \gamma(\sqrt{2I_{DSS}R_{SS} + 0.6} - \sqrt{0.6})$$

Solving iteratively with $R_{SS} = 220k\Omega$ | $K_n = 400 \frac{\mu A}{V^2}$ | $V_{TO} = 1V$ | $\gamma = 0.75\sqrt{V}$ yields

$$I_D = 20.3\mu A \quad | \quad V_{GS} - V_{TN} = 0.319V \quad | \quad V_{TN} = 2.74V \quad | \quad V_{GS} = 3.05V$$

$$V_{DS} = 12 - (330k\Omega)I_{DS} - (-V_{GS}) = 8.35V > 0.319V - \text{Active region} \quad | \quad Q\text{-pt} : (20.3\mu A, 8.35V)$$

$$(b) g_m = \frac{2I_D}{V_{GS} - V_{TN}} = \frac{2(20.3\mu A)}{0.319V} = 0.127mS \quad | \quad A_{dd} = -g_m R_D = -(0.127mS)(330k\Omega) = -41.9$$

$$A_{cc} = -\frac{g_m R_D}{1 + 2g_m(1 + \eta)R_{SS}} = -\frac{(0.127mS)(330k\Omega)}{1 + 2(0.127mS)(220k\Omega)} = -0.737 \quad \text{assuming } \eta = 0$$

$$\text{For a differential output : } A_{dm} = A_{dd} = -41.9 \quad | \quad A_{cm} = 0 \quad | \quad CMRR = \infty$$

$$\text{For a single - ended output : } A_{dm} = \frac{A_{dd}}{2} = -21.0 \quad | \quad A_{cm} = A_{cc} = -0.737$$

$$CMRR = \frac{21.0}{0.737} = 28.4 \quad | \quad CMRR_{db} = 29.1 \text{ dB} \quad | \quad R_{id} = \infty \quad | \quad R_{ic} = \infty$$