

**Homework Assignment No. 9 – Solutions****1.) Problem 17.1 (17.1) of the text.**

$$A_v(s) = 25 \frac{s^2}{(s+1)(s+20)} \quad | \quad A_{mid} = 25 \quad | \quad F_L(s) = \frac{s^2}{(s+1)(s+20)} \quad | \quad \text{Poles: } -1, -20 \quad | \quad \text{Zeros: } 0, 0$$

$$\text{yes, } s = -20 \quad | \quad A_v(s) \approx 25 \frac{s}{(s+20)} \quad | \quad \omega_L = 20 \frac{\text{rad}}{s} \quad | \quad f_L = \frac{\omega_L}{2\pi} \approx \frac{20}{2\pi} = 3.18 \text{ Hz}$$

$$f_L = \frac{1}{2\pi} \sqrt{20^2 + 1^2 - 2(0)^2 - 2(0)^2} = 3.19 \text{ Hz}$$

$$|A_v(j\omega)| = \frac{25\omega^2}{\sqrt{\omega^2 + 1^2} \sqrt{\omega^2 + 20^2}} \quad | \quad \text{MATLAB: } -3.19 \text{ Hz}$$

**2.) Problem 17.4 (17.4) of the text.**

$$A_v(s) = \frac{(2 \times 10^{11})(10^{-4})(10^{-5})}{\left(\frac{s}{10^4} + 1\right)\left(\frac{s}{10^5} + 1\right)} = \frac{200}{\left(\frac{s}{10^4} + 1\right)\left(\frac{s}{10^5} + 1\right)} \quad | \quad A_{mid} = 200 \quad | \quad F_H(s) = \frac{1}{\left(\frac{s}{10^4} + 1\right)\left(\frac{s}{10^5} + 1\right)}$$

$$\text{Poles: } -10^4, -10^5 \frac{\text{rad}}{s} \quad | \quad \text{Yes: } A_v(s) \approx \frac{200}{\frac{s}{10^4} + 1} \quad | \quad \omega_H \approx 10^4 \frac{\text{rad}}{s} \quad | \quad f_H \approx \frac{10^4}{2\pi} = 1.59 \text{ kHz}$$

$$f_H \approx \frac{1}{2\pi} \left( \sqrt{\left(\frac{1}{10^4}\right)^2 + \left(\frac{1}{10^5}\right)^2} - 2\left(\frac{1}{\infty}\right)^2 - 2\left(\frac{1}{\infty}\right)^2 \right)^{-1} = 1.58 \text{ kHz}$$

$$|A_v(j\omega)| = \frac{2 \times 10^{11}}{\sqrt{\omega^2 + (10^4)^2} \sqrt{\omega^2 + (10^5)^2}} \quad | \quad \text{MATLAB: } f_H = 1.58 \text{ kHz}$$

**3.) Problem 17.10 (17.10) of the text.**

(a.)

Low frequency:

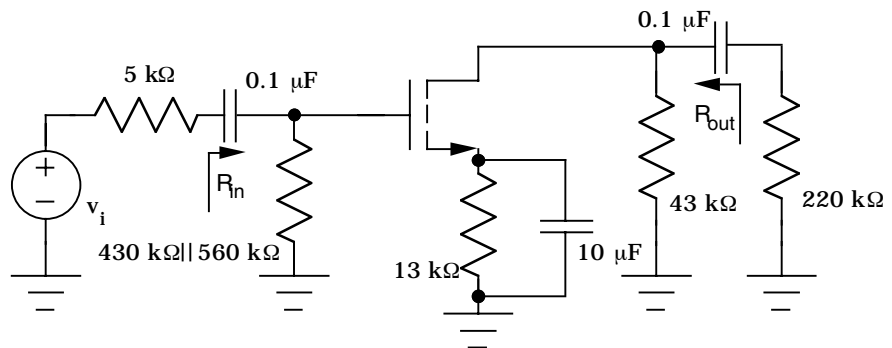

Mid-band:

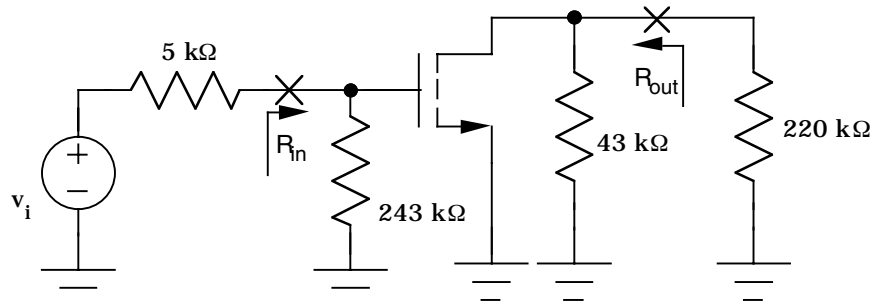

Problem 17.10 - Continued

(b.)

$$A_{vt} = \frac{v_d}{v_g} = -g_m R_L = -g_m (R_{out} \parallel R_3) \quad | \quad A_{mid} = \frac{R_{in}}{R_I + R_{in}} A_{vt} \quad | \quad g_m = \frac{2I_D}{V_{GS} - V_{TN}} = \frac{2(0.2mA)}{1V} = 0.400mS$$

$$R_{in} = 243k\Omega \quad | \quad R_{out} = R_D \parallel r_o \cong R_D = 43k\Omega \quad \text{assuming } \lambda = 0 \text{ since it is not specified.}$$

$$A_{mid} = -\left(\frac{243k\Omega}{5k\Omega + 243k\Omega}\right)(0.400mS)(43k\Omega \parallel 220k\Omega) = -14.1$$

$$\omega_1 = \frac{1}{(10^{-7}F)(243k\Omega + 5k\Omega)} = 40.3 \frac{rad}{s} \quad | \quad \omega_2 = \frac{1}{(10^{-7}F)(43k\Omega + 220k\Omega)} = 38.0 \frac{rad}{s}$$

$$\omega_3 = \frac{1}{(10^{-5}F)\left(13k\Omega \parallel \frac{1}{g_m}\right)} = \frac{1}{(10^{-5}F)(13k\Omega \parallel 2.5k\Omega)} = 47.7 \frac{rad}{s} \quad | \quad \omega_z = \frac{1}{(10^{-5}F)(13k\Omega)} = 7.69 \frac{rad}{s}$$

$$\text{Using Eq. (17.16): } f_L \cong \frac{1}{2\pi} \sqrt{(40.3)^2 + (38.0)^2 + (47.7)^2 - 2(7.69)^2} = 11.5 \text{ Hz}$$

4.) Problem 17.18 (17.13) of the text

(a.)

Mid-band:

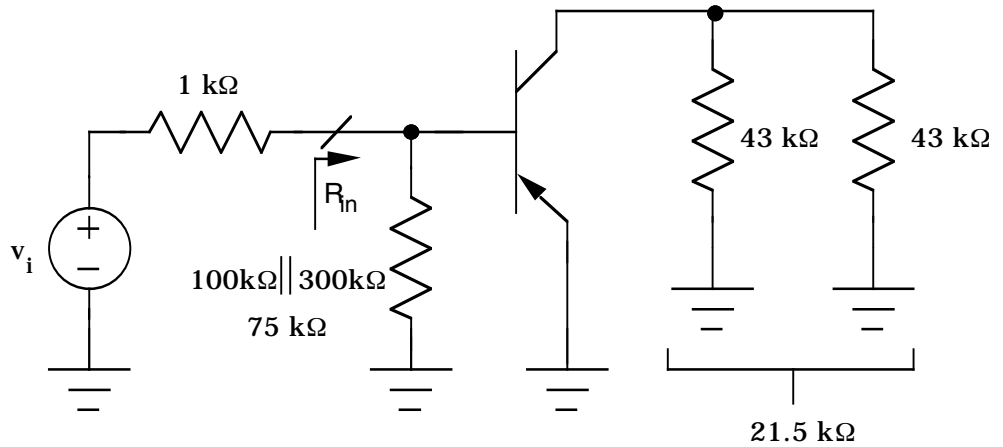

Low frequency:

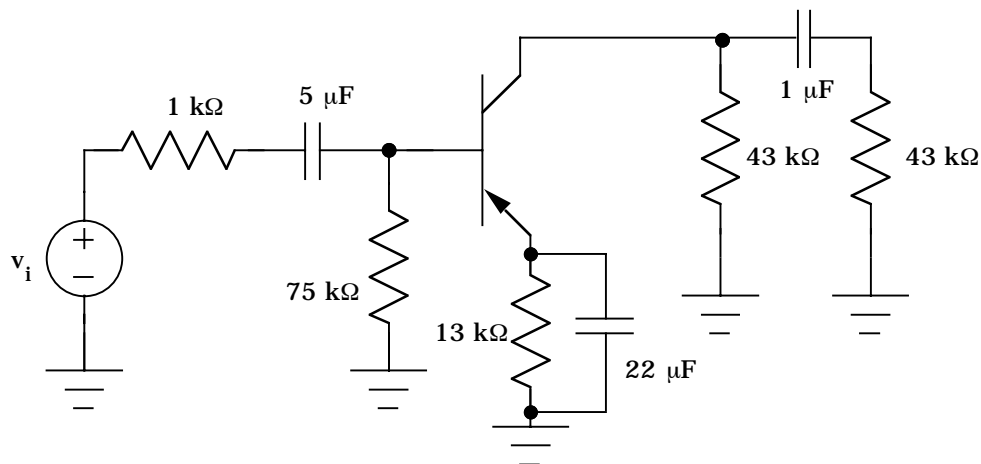

Problem 17.18 (17.13) - Continued

$$(b) g_m = 40I_C = 40(0.164mA) = 6.56mS \quad | \quad r_\pi = \frac{\beta_o}{g_m} = \frac{100}{6.56mS} = 15.2k\Omega \quad | \quad r_o = \infty \quad (V_A \text{ not given})$$

$$R_{in} = R_1 \| R_2 \| r_\pi = 100k\Omega \| 300k\Omega \| 15.2k\Omega = 12.6k\Omega \quad | \quad R_L = R_C \| R_3 = 43k\Omega \| 43k\Omega = 21.5k\Omega$$

$$A_{mid} = \frac{R_{in}}{R_I + R_{in}} g_m R_L = \frac{12.6k\Omega}{1k\Omega + 12.6k\Omega} (6.56mS)(21.5k\Omega) = -131$$

$$SCTC: R_{1S} = R_I + R_{in} = 1k\Omega + 12.6k\Omega = 13.6k\Omega \quad | \quad R_{th} = R_1 \| R_2 \| R_I = 100k\Omega \| 300k\Omega \| 1k\Omega = 987\Omega$$

$$R_{2S} = R_E \left\| \frac{R_{th} + r_\pi}{\beta_o + 1} \right\| = 13k\Omega \left\| \frac{987\Omega + 15.2k\Omega}{101} \right\| = 158\Omega \quad | \quad R_{3S} = R_C + R_3 = 43k\Omega + 43k\Omega = 86k\Omega$$

$$f_L \cong \frac{1}{2\pi} \left[ \frac{1}{5 \times 10^{-6}(13.6k\Omega)} + \frac{1}{22 \times 10^{-6}(158\Omega)} + \frac{1}{1 \times 10^{-6}(86k\Omega)} \right] = \frac{(14.7 + 288 + 11.6)}{2\pi} = 50.0 \text{ Hz}$$

5.) Problem 17.23 (17.16) of the text.

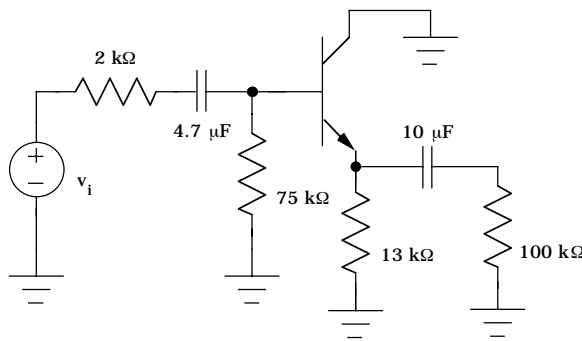

Low frequency

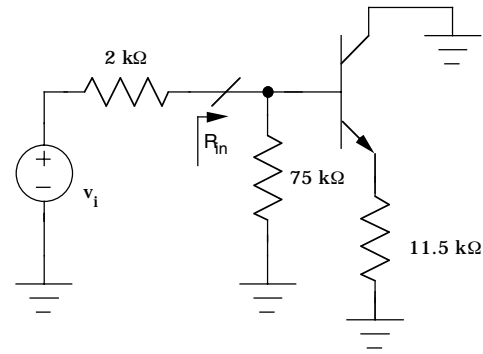

Mid-band

$$(b) R_{in} = R_1 \| R_2 \| r_\pi + (\beta_o + 1)R_L \quad | \quad R_L = 13k\Omega \| 100k\Omega = 11.5k\Omega \quad | \quad r_\pi = \frac{100}{40(0.25mA)} = 10.0k\Omega$$

$$R_{in} = R_1 \| R_2 \| [r_\pi + (\beta_o + 1)R_L] = 100k\Omega \| 300k\Omega \| [10.0k\Omega + (101)11.5k\Omega] = 70.5k\Omega$$

$$A_{mid} = \frac{R_{in}}{R_I + R_{in}} \frac{(\beta_o + 1)R_L}{R_{in}} = 0.972 \frac{101(11.5k\Omega)}{[2 + 10.0 + 101(11.5)]k\Omega} = 0.963 \quad | \quad R_B = R_1 \| R_2 = 75k\Omega$$

$$R_{1S} = R_I + R_B \| [r_\pi + (\beta_o + 1)R_L] = 2k\Omega + 75k\Omega \| [10.0k\Omega + (101)11.5k\Omega] = 72.5k\Omega$$

$$\omega_1 = \frac{1}{(72.5k\Omega)4.7 \times 10^{-6}} = 2.94 \frac{rad}{s}$$

$$R_{3S} = R_7 + R_E \left\| \frac{R_B \| R_I + r_\pi}{(\beta_o + 1)} \right\| = 100k\Omega + 13k\Omega \left\| \frac{1.95k\Omega + 10.0k\Omega}{101} \right\| = 100k\Omega$$

$$\omega_3 = \frac{1}{10^{-5}(10^5)} = 1 \frac{rad}{s} \quad f_L \cong \frac{(2.94 + 1)}{2\pi} = 0.627 \text{ Hz}$$