

Homework Assignment No. 12 - Solutions

1.) Problem 18.23 (18.16) of the text.

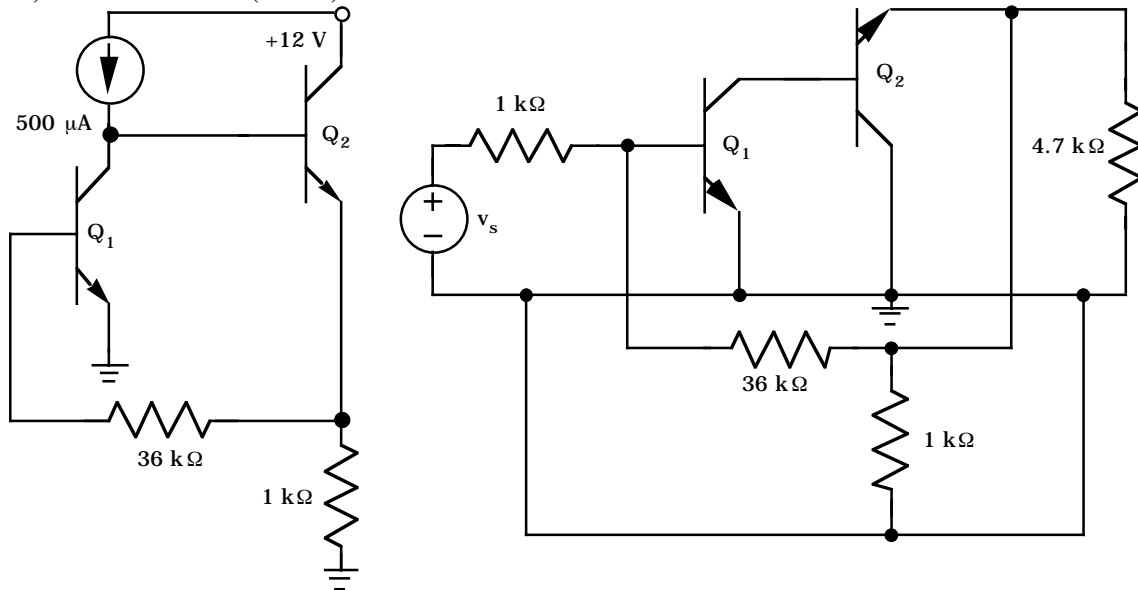

$$I_{C1} = 500\mu\text{A} - I_{B2} \quad I_{E2} = I_{B1} + \frac{36000I_{B1} + 0.7}{1000} = 37I_{B1} + 700\mu\text{A} \quad I_{B2} = \frac{I_{E2}}{101}$$

$$I_{C1} = 500\mu\text{A} - \frac{37I_{B1} + 700\mu\text{A}}{101} = 493\mu\text{A} - 0.366I_{B1} \rightarrow I_{C1} = 491.2\mu\text{A}$$

$$I_{E2} = 37 \frac{I_{C1}}{100} + 700\mu\text{A} = 881.7\mu\text{A} \quad I_{C2} = \frac{100}{101} I_{E2} = 873\mu\text{A}$$

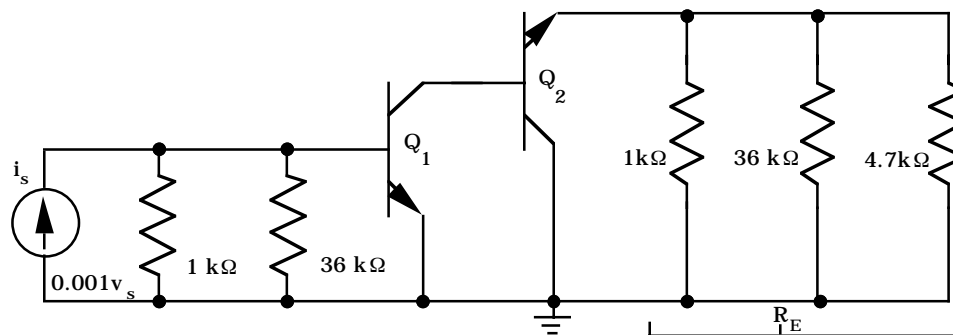

$$y_{11}^F = \frac{\mathbf{i}_1}{\mathbf{v}_1} \Big|_{\mathbf{v}_2=0} = \frac{1}{36\text{k}\Omega} \quad | \quad y_{22}^F = \frac{\mathbf{i}_2}{\mathbf{v}_2} \Big|_{\mathbf{v}_1=0} = \frac{1}{36\text{k}\Omega \parallel 1\text{k}\Omega} \quad | \quad y_{12}^F = \frac{\mathbf{i}_1}{\mathbf{v}_2} \Big|_{\mathbf{v}_1=0} = -\frac{1}{36\text{k}\Omega}$$

$$r_{\pi 1} = \frac{100(0.025)}{491\mu\text{A}} = 5.09\text{k}\Omega \quad | \quad r_{\pi 2} = \frac{100(0.025)}{873\mu\text{A}} = 2.86\text{k}\Omega \quad | \quad r_{o1} = \frac{50 + 1.6}{493 \times 10^{-6}} = 105\text{k}\Omega$$

$$R_E = (1\text{k}\Omega \parallel 36\text{k}\Omega \parallel 4.7\text{k}\Omega) = 807\Omega$$

$$A = \frac{\mathbf{v}_o}{\mathbf{i}_s} = (1\text{k}\Omega \parallel 36\text{k}\Omega \parallel r_{\pi 1}) g_{m1} \left[r_{o1} \parallel (r_{\pi 2} + (\beta_o + 1)R_E) \right] \frac{r_{\pi 2} + (\beta_o + 1)R_E}{r_{o1} + r_{\pi 2} + (\beta_o + 1)R_E}$$

Problem 18.23 (18.16) - Continued

$$A = \frac{\mathbf{v}_o}{\mathbf{i}_s} = -\left(1\text{k}\Omega \parallel 36\text{k}\Omega \parallel 5.09\text{k}\Omega\right) g_{m1} \left[r_{o1} \parallel \left(r_{\pi 2} + (\beta_o + 1)R_E \right) \right] \frac{r_{\pi 2} + (\beta_o + 1)R_E}{r_{o1} + r_{\pi 2} + (\beta_o + 1)R_E}$$

$$\left(1\text{k}\Omega \parallel 36\text{k}\Omega \parallel r_{\pi 1}\right) = \left(1\text{k}\Omega \parallel 36\text{k}\Omega \parallel 5.09\text{k}\Omega\right) = 817\Omega \quad | \quad g_m = 40(491\mu\text{A}) = 19.6\text{mS}$$

$$\left[r_{o1} \parallel \left(r_{\pi 2} + (\beta_o + 1)R_E \right) \right] = \left[105\text{k}\Omega \parallel \left(2.86\text{k}\Omega + (101)806\Omega \right) \right] = 46.8\text{k}\Omega$$

$$\frac{r_{\pi 2} + (\beta_o + 1)R_E}{r_{o1} + r_{\pi 2} + (\beta_o + 1)R_E} = \frac{2.86\text{k}\Omega + (101)806\Omega}{105\text{k}\Omega + 2.86\text{k}\Omega + (101)806\Omega} = 0.430$$

$$A = -(817\Omega)(19.6\text{mS})(46.8\text{k}\Omega)(0.430) = -322\text{k}\Omega$$

$$A_{\text{TR}} = \frac{A}{1 + A\beta} = \frac{-322\text{k}\Omega}{1 + (-322\text{k}\Omega)\left(-\frac{1}{36\text{k}\Omega}\right)} = -\frac{322\text{k}\Omega}{9.94} = -32.4\text{k}\Omega$$

$$R_{\text{IN}} = \frac{\left(1\text{k}\Omega \parallel 36\text{k}\Omega \parallel 5.09\text{k}\Omega\right)}{1 + A\beta} = \frac{817\Omega}{9.94} = 82.2\Omega$$

$$R_{\text{OUT}} = \frac{\left(1\text{k}\Omega \parallel 36\text{k}\Omega \parallel 4.7\text{k}\Omega \parallel \frac{r_{\pi 2} + r_{o1}}{101}\right)}{1 + A\beta} = \frac{\left(806\Omega \parallel \frac{2.86\text{k}\Omega + 105\text{k}\Omega}{101}\right)}{9.94} = 46.2\Omega$$

$$\mathbf{i}_s = 10^{-3} \mathbf{v}_s \rightarrow A_V = \frac{\mathbf{v}_o}{\mathbf{v}_s} = \frac{\mathbf{v}_o}{1000\mathbf{i}_s} = -32.4$$

Note that this amplifier can be analyzed as a shunt-shunt feedback amplifier. This is good for student practice - See Problem 18.32 (18.25).

2.) A shunt-shunt feedback amplifier is shown. Use the methods of feedback analysis to find the numerical values of v_2/v_1 , v_1/i_1 , and v_2/i_2 . For Q1, assume that $h_{fe} = 100$, $g_m = 50\text{mS}$ and $r_o = \infty$. For M2, assume that $g_m = 1\text{mS}$ and $r_{ds} = \infty$.

Solution

Quasi-ac model of this circuit.

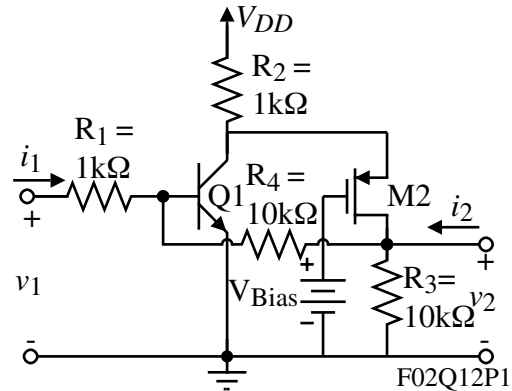
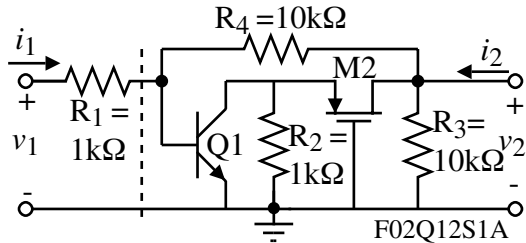

The feedback β is given as

$$\beta = g_{12F} = \frac{i_{1F}}{v_{2F}} \Big|_{v_{1F}=0} = \frac{-1}{R_4} = \frac{-1}{10\text{K}}$$

The open-loop circuit to calculate A is given as,

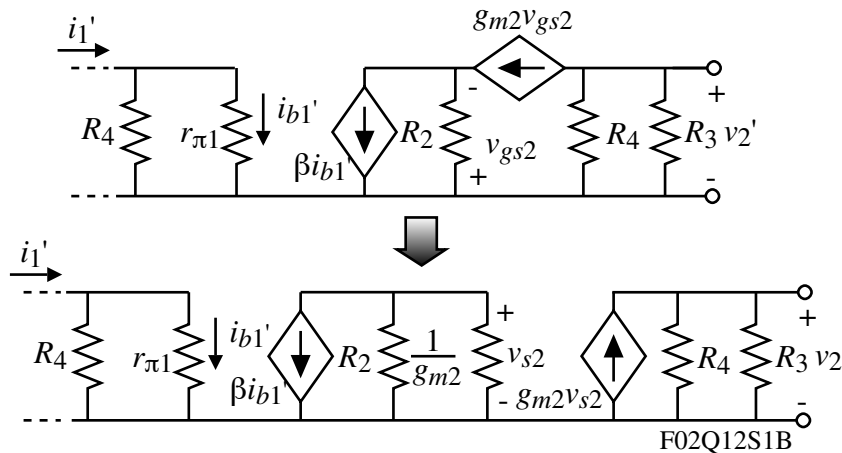

$$A = \frac{v_2'}{i_1'} = \left(\frac{v_2'}{v_{s2}'} \right) \left(\frac{v_{s2}'}{i_{b1}'} \right) \left(\frac{i_{b1}'}{i_1'} \right) = (g_{m2} \cdot R_3 \parallel R_4) [-\beta_1 \cdot R_2 \parallel (1/g_{m2})] \left(\frac{R_4}{R_4 + r_{\pi 1}} \right)$$

$$= (5)(-50\text{K})(10/12) = -208.33\text{k}\Omega \quad (r_{\pi 1} = \frac{100}{50\text{mS}} = 2\text{k}\Omega)$$

$$A_F = \frac{v_2}{i_1} = \frac{A}{1+A\beta} = \frac{-208.33\text{K}}{1+(-208.33\text{K}/-10\text{K})} = \frac{-208.33\text{K}}{1+20.833} = \frac{-208.33\text{K}}{21.833} = -9.542\text{k}\Omega$$

$$R_{in} = R_4 \parallel r_{\pi 1} = 2\text{k} \parallel 10\text{K} = 1.67\text{K} \quad \rightarrow R_{inF} = \frac{1.67\text{k}}{21.833} = 76.34\Omega$$

$$\therefore \frac{v_1}{i_1} = 1\text{k}\Omega + 76.34\Omega = \underline{1.076\text{k}\Omega} \quad \frac{v_2}{v_1} = \left(\frac{v_2}{i_1} \right) \left(\frac{i_1}{v_1} \right) = \frac{-9.542\text{k}\Omega}{1.076\text{k}\Omega} = \underline{-8.652 \text{ V/V}}$$

$$R_{out} = R_3 \parallel R_4 = 5\text{k}\Omega \quad \rightarrow \frac{v_2}{i_2} = \frac{5\text{k}\Omega}{21.833} = \underline{229\Omega}$$

3.) For each of the MOSFET amplifiers shown below, show how to connect a single resistor from the output to the input that achieves a series-shunt, series-series, shunt-shunt and shunt-series negative feedback amplifier. For each of the four configurations, identify on the schematic the correct variables (x_s , x_f , x_i , and x_o). The outputs should be at the drain or source of M3.

Solution

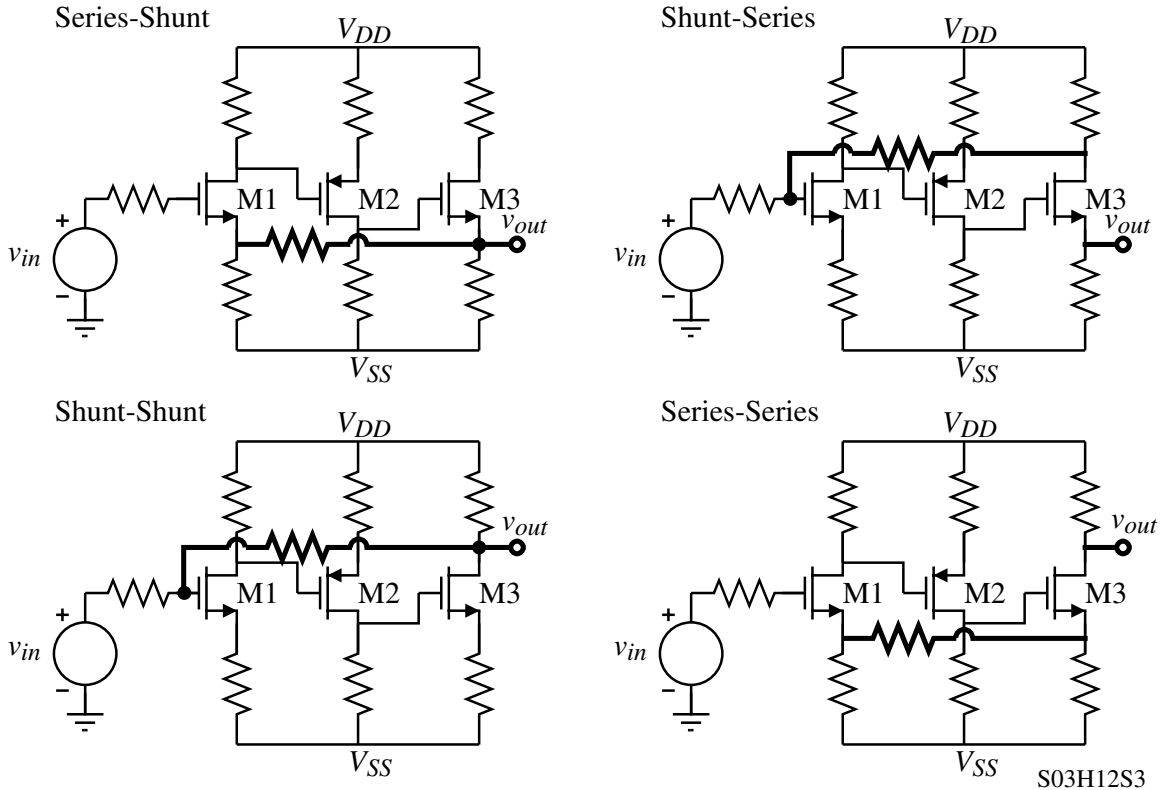

4.) Problem 18.29 (18.22) of the text (Shunt series).

$$y_{11}^F = \frac{\mathbf{i}_1}{\mathbf{v}_1} \Big|_{\mathbf{v}_2=0} = 10^{-6} \text{ S} \quad | \quad y_{22}^F = \frac{\mathbf{i}_2}{\mathbf{v}_2} \Big|_{\mathbf{v}_1=0} = 10^{-6} \text{ S} \quad | \quad y_{12}^F = \frac{\mathbf{i}_1}{\mathbf{v}_2} \Big|_{\mathbf{v}_1=0} = -10^{-6} \text{ S}$$

$$\mathbf{v}_{gs} = \mathbf{i}_s (100 \text{ k}\Omega \parallel 1 \text{ M}\Omega) = (90.9 \text{ k}\Omega) \mathbf{i}_s \quad | \quad \mathbf{v}_o = -(2 \times 10^{-3}) \mathbf{v}_{gs} (40 \text{ k}\Omega \parallel 10 \text{ k}\Omega \parallel 10 \text{ k}\Omega \parallel 1 \text{ M}\Omega)$$

$$A = \frac{\mathbf{v}_o}{\mathbf{i}_s} = -(2 \text{ mS})(4.44 \text{ k}\Omega)(90.9 \text{ k}\Omega) = -8.08 \times 10^5$$

$$A_{TR} = \frac{A}{1 + A\beta} = \frac{-8.08 \times 10^5}{1 + (-8.08 \times 10^5)(-10^{-6})} = \frac{-8.08 \times 10^5}{1.81} = -446 \text{ k}\Omega$$

$$R_{IN} = \frac{(100 \text{ k}\Omega \parallel 1 \text{ M}\Omega)}{(1 + A\beta)} = \frac{90.9 \text{ k}\Omega}{1.81} = 50.2 \text{ k}\Omega$$

$$R_{OUT} = \frac{(40 \text{ k}\Omega \parallel 10 \text{ k}\Omega \parallel 10 \text{ k}\Omega \parallel 1 \text{ M}\Omega)}{(1 + A\beta)} = \frac{4.44 \text{ k}\Omega}{1.81} = 2.45 \text{ k}\Omega$$