

Homework Assignment No. 11

Due Friday, April 8, 2005 in class

Problem 1 - (10 points)

Problem 8.26 of GHLM

Problem 2 - (10 points)

The simplified schematic of a feedback amplifier is shown. Use the method of feedback analysis to find V_2/V_1 , $R_{in} = V_1/I_1$, and $R_{out} = V_2/I_2$. Assume that all transistors are matched and that $g_m = 1\text{mA/V}$ and $r_{ds} = \infty$.

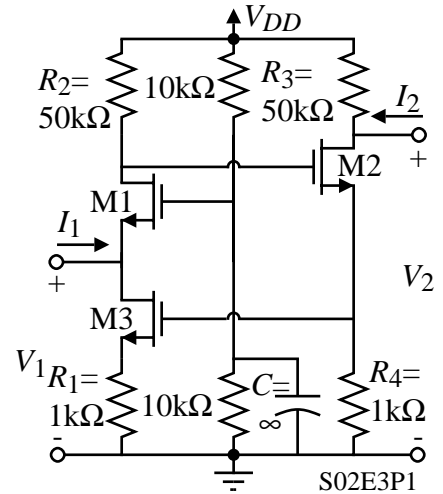

Problem 3 – (10 points)

Problem 8.30 of GHLM

Problem 4 - (10 points)

Use the Blackman's formula (see below) to calculate the small-signal output resistance of the stacked MOSFET configuration having identical drain-source drops for both transistors. Express your answer in terms of all the pertinent small-signal parameters and then simplify your answer if $g_m \gg g_{ds} \gg (1/R)$. Assume the MOSFETs are identical.

$$R_{out} = R_{out}(g_m=0) \left[\frac{1 + RR(\text{output port shorted})}{1 + RR(\text{output port open})} \right]$$

(You may use small-signal analysis if you wish but this circuit seems to be one of the rare cases where feedback analysis is more efficient.)

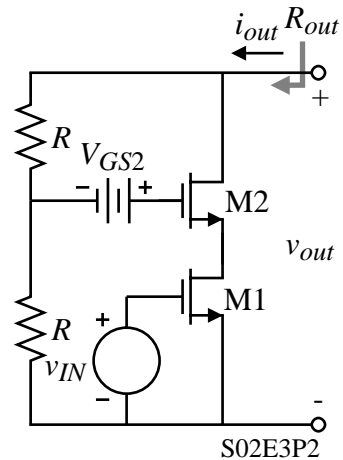

Problem 5 – (10 points)

Problem 7.1-10 of Allen and Holberg, 2nd edition.