

EXAMINATION NO. 1

NAME _____ SCORE _____ /100

INSTRUCTIONS: This exam is closed book with one sheet of notes permitted. The exam consists of 4 questions for a total of 100 points. Please show your work leading to your answers so that maximum partial credit may be given where appropriate. Be sure to turn in your exam with the problems in numerical order, firmly attached together.

Problem 1 - (25 points)

Six versions of a source follower are shown below. Assume that $K'_N = 2K'_P$, $\lambda_P = 2\lambda_N$, all W/L ratios of all devices are equal, and that all bias currents in each device are equal. Neglect bulk effects in this problem and assume no external load resistor. Identify which circuit or circuits have the following characteristics: (a.) highest small-signal voltage gain, (b.) lowest small-signal voltage gain, (c.) the highest output resistance, (d.) the lowest output resistance, (e.) the highest $v_{out(max)}$ and (f.) the lowest $v_{out(max)}$.

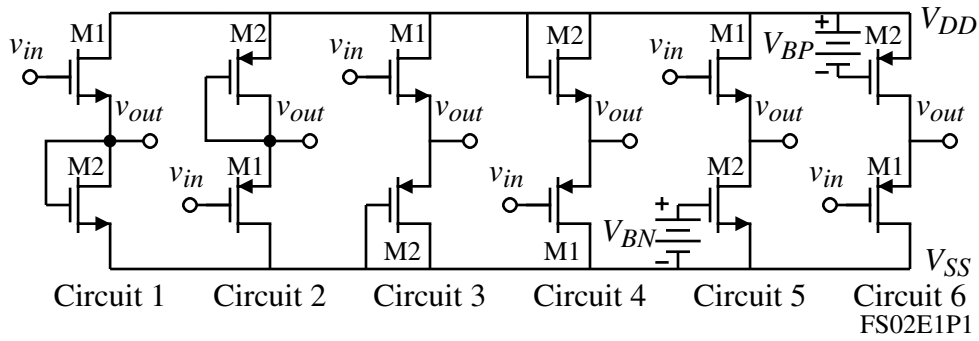

Problem 2 - (25 points)

An output stage using both MOSFETs and a BJT is shown. Assume the transistor parameters are $K_N' = 110\mu\text{A}/\text{V}^2$, $V_T = 0.7\text{V}$, and $\lambda_N = 0.04\text{V}^{-1}$ for the NMOS; $K_P' = 50\mu\text{A}/\text{V}^2$, $V_T = -0.7\text{V}$, and $\lambda_P = 0.05\text{V}^{-1}$ for the PMOS and $\beta_F = 100$, $V_t = 0.025\text{V}$, and $I_s = 10\text{fA}$ for the NPN BJT. (a.) If v_{in} can vary between $\pm 2\text{V}$, what is the maximum positive and negative value of i_{out} when $R_L = 0\Omega$? (b.) If v_{in} can vary between $\pm 2\text{V}$, what is the maximum and minimum output voltage when $R_L = 100\Omega$?

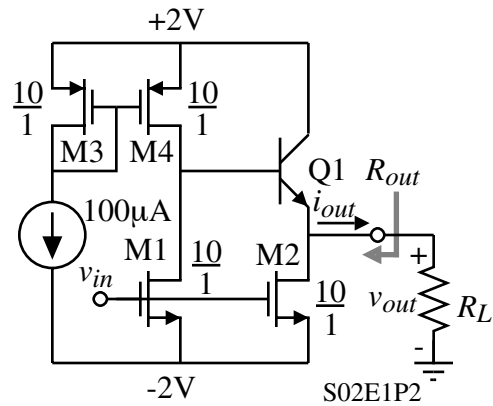

Problem 3 - (25 points)

Find the midband voltage gain and the -3dB frequency in Hertz for the circuit shown.

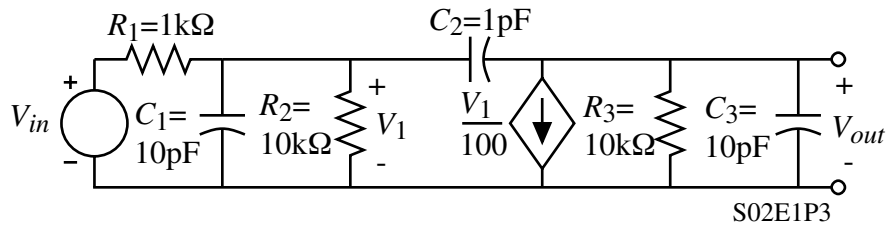

Problem 4 - (25 points)

Find the midband voltage gain and the exact value of the two poles of the voltage transfer function for the circuit shown. Assume that $R_I = 1\text{k}\Omega$, $R_L = 10\text{k}\Omega$, $g_m = 1\text{mS}$, $C_{gs} = 5\text{pF}$ and $C_{gd} = 1\text{pF}$. Ignore r_{ds} .

