

Homework Assignment No. 3

Due Wednesday, January 29, 2003 in class

Problem 1 - (10 points) (Prob. 7.1 of 3rd and 4th edition)

(a) Use the Miller approximation to calculate the -3dB frequency of the small-signal voltage gain of a common-emitter transistor stage as shown in Fig. 7.2a using the following transistor parameters:

$$R_S = 5\text{k}\Omega \quad r_b = 300\Omega \quad I_C = 0.5\text{mA} \quad \beta = 200 \quad f_T = 500\text{MHz (at } I_C = 0.5\text{mA)}$$

$$C_\mu = 0.3\text{pF} \quad R_L = 3\text{k}\Omega \quad C_{cs} = 0 \quad V_A = \infty$$

(b) Calculate the nondominant pole magnitude for the circuit in (a). Compare your answer with a SPICE simulation.

Problem 2 - (10 points) (Prob. 7.2 of 4th edition)

Repeat Problem 1 for the MOS common-source stage shown using $R_I = 10\text{k}\Omega$, $R_L = 5\text{k}\Omega$, $I_D = 0.5\text{mA}$, and the following NMOS transistor data:

$$W = 100\mu\text{m}, \quad L_{\text{drawn}} = 2\mu\text{m}, \quad L_d = 0.2\mu\text{m}, \quad X_d = 0,$$

$$\lambda = 0, \quad k'_n = 60\mu\text{A/V}^2, \quad \gamma = 0, \quad C_{sb} = C_{db} = 0,$$

$$C_{ox} = 0.7\text{fF}/\mu\text{m}^2, \quad \text{and } C_{gd} = 14\text{fF}.$$

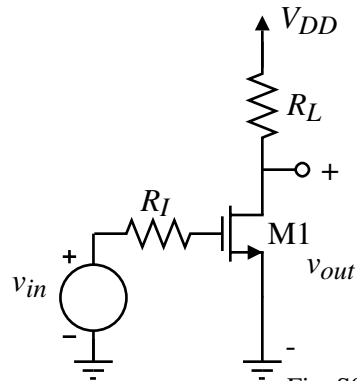

Fig. S02H3P2

Problem 3 - (10 points) (Prob. 7.5 of 3rd and 7.8 of the 4th edition)

A lateral *npn* emitter follower has $R_S = 250\Omega$, $r_b = 200\Omega$, $\beta = 50$, $I_C = -300\mu\text{A}$, $f_T = 4\text{MHz}$, $R_E = 4\text{k}\Omega$, $C_\mu = 0$, and $r_o = \infty$. Calculate the small-signal voltage gain as a function of frequency. Sketch the magnitude of the voltage gain in decibels from $f = 10\text{kHz}$ to $f = 20\text{MHz}$, using a log frequency scale.

Problem 4 - (10 points) (Prob. 7.6 of 3rd and 7.9 of the 4th edition)

Calculate the values of the elements in the small-signal equivalent circuits for the input and output impedances of the emitter follower of the previous problem. Sketch the magnitudes of these impedances as a function of frequency from $f = 10\text{kHz}$ to $f = 20\text{MHz}$, using log frequency scales. Use SPICE to determine the small-signal step response of the circuit for a resistive load of $1\text{k}\Omega$ and then a capacitive load of 400pF . Use a 1-mV input pulse amplitude with zero rise time. Comment on the shape of the time-domain responses. (Bias the circuit with an ideal $300\mu\text{A}$ current source connected to the emitter for the capacitive load test.)

Problem 5 - (10 points)

Find the midband voltage gain and the -3dB frequency in Hertz for the circuit shown.

