

Homework No. 5 - Solutions

Problem 1 - (10 points) (Problem 6.2-8 of A&H)

A two-stage, Miller-compensated CMOS op amp has a RHP zero at $20GB$, a dominant pole due to the Miller compensation, a second pole at p_2 and a mirror pole at $-3GB$. (a) If GB is 1MHz, find the location of p_2 corresponding to a 45° phase margin. (b) Assume that in part (a) that $|p_2| = 2GB$ and a nulling resistor is used to cancel p_2 . What is the new phase margin assuming that $GB = 1\text{MHz}$? (c) Using the conditions of (b), what is the phase margin if C_L is increased by a factor of 4?

Solution

a.) Since the magnitude of the op amp is unity at GB , then let $\omega = GB$ to evaluate the phase.

$$\text{Phase margin} = \text{PM} = 180^\circ - \tan^{-1}\left(\frac{GB}{|p_1|}\right) - \tan^{-1}\left(\frac{GB}{|p_2|}\right) - \tan^{-1}\left(\frac{GB}{|p_3|}\right) - \tan^{-1}\left(\frac{GB}{|z_1|}\right)$$

But, $p_1 = GB/A_0$, $p_3 = -3GB$ and $z_1 = -20GB$ which gives

$$\text{PM} = 45^\circ = 180^\circ - \tan^{-1}(A_0) - \tan^{-1}\left(\frac{GB}{|p_2|}\right) - \tan^{-1}(0.33) - \tan^{-1}(0.05)$$

$$45^\circ \approx 90^\circ - \tan^{-1}\left(\frac{GB}{|p_2|}\right) - \tan^{-1}(0.33) - \tan^{-1}(0.05) = 90^\circ - \tan^{-1}\left(\frac{GB}{|p_2|}\right) - 18.26^\circ - 2.86^\circ$$

$$\therefore \tan^{-1}\left(\frac{GB}{|p_2|}\right) = 45^\circ - 18.26^\circ - 2.86^\circ = 23.48^\circ \rightarrow \frac{GB}{|p_2|} = \tan(23.84^\circ) = 0.442$$

$$\boxed{p_2 = -2.26 \cdot GB = -14.2 \times 10^6 \text{ rads/sec}}$$

b.) The only roots now are p_1 and p_3 . Thus,

$$\boxed{\text{PM} = 180^\circ - 90^\circ - \tan^{-1}(0.33) = 90^\circ - 18.3^\circ = 71.7^\circ}$$

c.) In this case, z_1 is at $-2GB$ and p_2 moves to $-0.5GB$. Thus the phase margin is now,

$$\boxed{\text{PM} = 90^\circ - \tan^{-1}(2) + \tan^{-1}(0.5) - \tan^{-1}(0.33) = 90^\circ - 63.43^\circ + 26.57^\circ - 18.3^\circ = 34.4^\circ}$$

Problem 2 – (Problem 6.2-10 of A&H)

For the two-stage op amp of Fig. 6.2-8, find W_1/L_1 , W_6/L_6 , and C_c if $GB = 1$ MHz, $|p_2| = 5 GB$, $z = 3 GB$ and $C_L = C_2 = 20$ pF. Use the parameter values of Table 3.1-2 and consider only the two-pole model of the op amp. The bias current in M5 is $40 \mu\text{A}$ and in M7 is $320 \mu\text{A}$.

Solution

Given

$$GB = 1 \text{ MHz.}$$

$$p_2 = 5GB$$

$$z = 3GB$$

$$C_L = C_2 = 20 \text{ pF}$$

$$\text{Now, } p_2 = \frac{g_{m6}}{C_2}$$

or,

$$g_{m6} = 628.3 \mu\text{S}$$

or,

$$\left(\frac{W}{L}\right)_6 = \frac{g_{m6}^2}{2K'_p I_{D6}} \cong 12.33$$

RHP zero is given by

$$z = \frac{g_{m6}}{C_c}$$

or,

$$C_c = \frac{g_{m6}}{z} = 33.3 \text{ pF}$$

Finally, Gain-bandwidth is given by

$$GB = \frac{g_{m1}}{C_c}$$

or,

$$g_{m1} = 209.4 \mu\text{S}$$

or,

$$\left(\frac{W}{L}\right)_1 = \frac{g_{m1}^2}{2K'_n I_{D1}} \cong 10$$

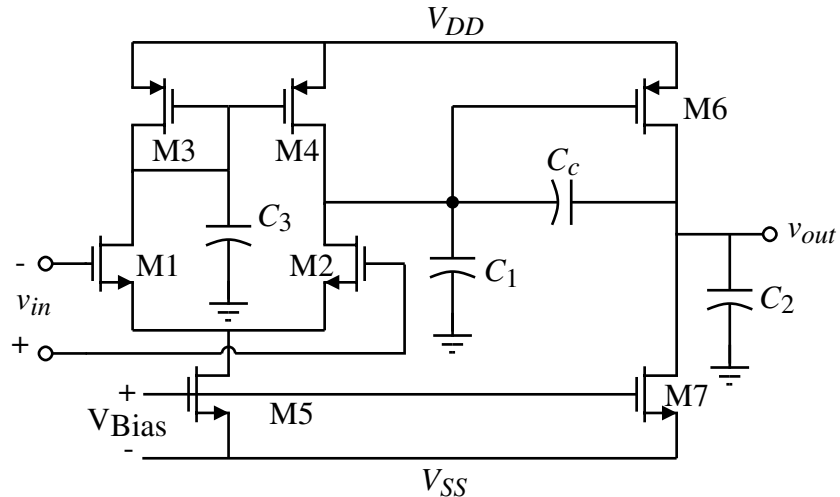
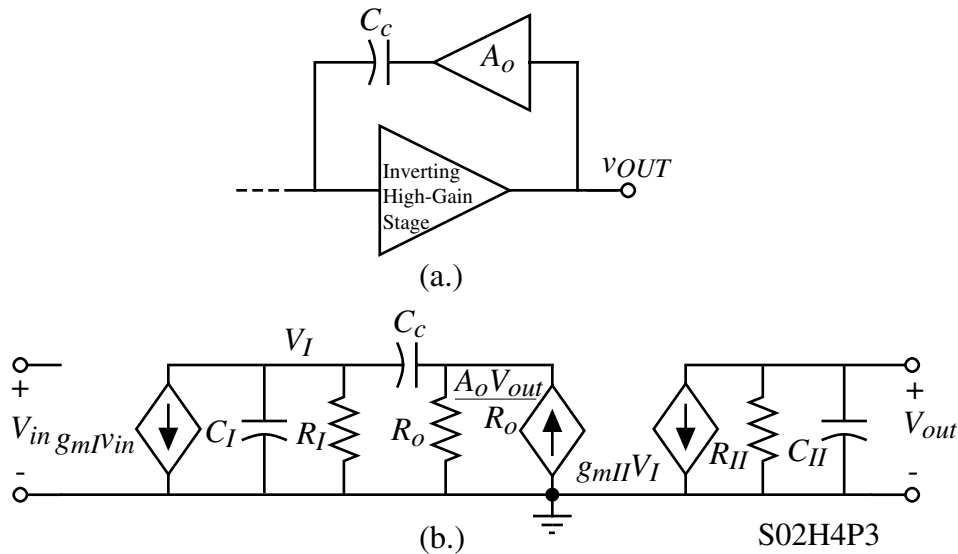

Figure 6.2-8 A two-stage op amp with various parasitic and circuit capacitances shown.

Problem 3 - (10 points) (Problem 6.2-11 of A&H)

In the figure shown, assume that $R_I = 150 \text{ k}\Omega$, $R_{II} = 100 \text{ k}\Omega$, $g_{mII} = 500 \mu\text{S}$, $C_I = 1 \text{ pF}$, $C_{II} = 5 \text{ pF}$, and $C_c = 30 \text{ pF}$. Find the value of R_z and the locations of all roots for (a) the case where the zero is moved to infinity and (b) the case where the zero cancels the highest pole.

Solution

(a.) Zero at infinity.

$$R_z = \frac{1}{g_{mII}} = \frac{1}{500 \mu\text{S}}$$

$$R_z = 2 \text{ k}\Omega$$

Check pole due to R_z .

$$p_4 = \frac{-1}{R_z C_I} = \frac{-1}{2 \text{ k}\Omega \cdot 1 \text{ pF}} = -500 \times 10^6 \text{ rps or } 79.58 \text{ MHz}$$

The pole at p_2 is

$$p_2 \approx \frac{-g_{mII} C_c}{C_I C_{II} + C_c C_I + C_c C_{II}} \approx \frac{-g_{mII}}{C_{II}} = \frac{-500 \mu\text{S}}{5 \text{ pF}} = 100 \times 10^6 \text{ rps or } 15.9 \text{ MHz}$$

Therefore, p_2 is the next highest pole.

(b.) Zero at p_2 .

$$R_z = \left(\frac{C_c + C_{II}}{C_c} \right) (1/g_{mII}) = \left(\frac{30+5}{30} \right) \frac{1}{500 \mu\text{S}} = 2.33 \text{ k}\Omega$$

$$R_z = 2.33 \text{ k}\Omega$$

Problem 4 – (10 points)

The poles and zeros of a Miller compensated, two-stage op amp are shown below.

(a.) If the influence of p_3 and z_1 are ignored, what is the GB in MHz of this op amp for 60° phase margin?

(b.) What is the value of $A_v(0)$? What is the value of C_c if $g_{m1}=g_{m2}=500\mu\text{S}$?

(c.) If p_2 is moved to p_3 , what is the new GB in MHz for 60° phase margin? What is the new C_c if the input transconductances are the same as in (b.)?

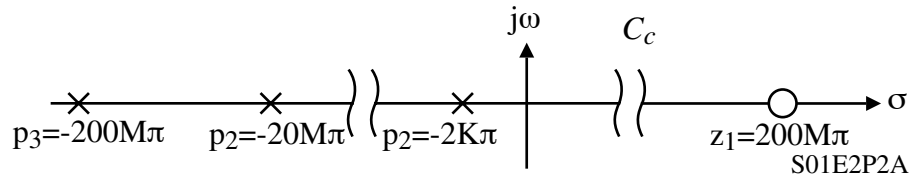
Solution

(a.) The phase margin, PM, can be written as

$$\text{PM} = 180 - \tan^{-1}\left(\frac{GB}{|p_2|}\right) - \tan^{-1}\left(\frac{GB}{|p_3|}\right) - \tan^{-1}\left(\frac{GB}{z_1}\right) \approx 90^\circ - \tan^{-1}\left(\frac{GB}{|p_2|}\right) = 60^\circ$$

$$\therefore \tan^{-1}\left(\frac{GB}{|p_2|}\right) = 30^\circ \quad \rightarrow \quad GB = 0.5774 \cdot |p_2| = \underline{\underline{5.774\text{MHz}}}$$

$$(b.) A_v(0) = \frac{GB}{|p_1|} = \frac{5.774\text{MHz}}{1\text{kHz}} = \underline{\underline{5,774\text{V/V}}}$$

$$\frac{g_{m1}}{C_c} = GB \quad \rightarrow \quad C_c = \frac{g_{m1}}{GB} = \frac{500\mu\text{S}}{2\text{p} \cdot 5.774 \times 10^6} = \underline{\underline{13.78\text{pF}}}$$

(c.) The phase margin, PM, can be written as

$$\text{PM} = 180 - \tan^{-1}\left(\frac{GB}{|p_2|}\right) - \tan^{-1}\left(\frac{GB}{|p_3|}\right) - \tan^{-1}\left(\frac{GB}{z_1}\right) \approx 90^\circ - 3 \cdot \tan^{-1}\left(\frac{GB}{|p_2|}\right) = 60^\circ$$

$$\therefore \tan^{-1}\left(\frac{GB}{|p_2|}\right) = 10^\circ \quad \rightarrow \quad GB = 0.1763 \cdot |p_2| = 0.01763 \cdot 100\text{MHz} = \underline{\underline{17.63\text{MHz}}}$$

$$C_c = \frac{g_{m1}}{GB} = \frac{500\mu\text{S}}{2\text{p} \cdot 17.63 \times 10^6} = \underline{\underline{4.514\text{pF}}}$$