

EXAMINATION NO. 1

NAME _____ SCORE _____ /100

INSTRUCTIONS: This exam is closed book with one sheet of notes permitted. The exam consists of 4 questions for a total of 100 points. Please show your work leading to your answers so that maximum partial credit may be given where appropriate. Be sure to turn in your exam with the problems in numerical order, firmly attached together.

Problem 1 - (25 points)

A push-pull follower is shown with a 500Ω load. Assume that the MOSFETs have the following model parameters: $K_N' = 100\mu\text{A}/\text{V}^2$, $V_{TN} = 0.5\text{V}$, and $K_P' = 50\mu\text{A}/\text{V}^2$, $V_{TP} = -0.5\text{V}$. Ignore the bulk effects and assume $\lambda = 0$.

a.) Find the small signal voltage gain and the output resistance (not including R_L) for the conditions of part a.) if the dc current in M1 and M2 is $100\mu\text{A}$.

b.) What is the output voltage when $v_{IN} = 0.5\text{V}$?

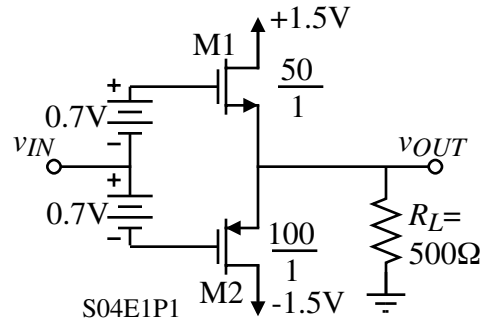

Problem 2 - (25 points)

An all-*npn* Darlington output stage is shown. For all devices assume that $V_{BE(on)} = 0.7V$, $V_{CE(sat)} = 0.2V$, and $\beta_F = 100$. The magnitude of the collector current in $Q3$ is 2mA.

a.) If $R_L = 8\Omega$, calculate the maximum positive and negative limits of v_{OUT} .

b.) Calculate the power dissipated in the circuit for $v_{OUT} = 0V$.

c.) Calculate the maximum average power that can be delivered to $R_L = 8\Omega$ before clipping occurs and the corresponding efficiency of the *complete* circuit. Assume that feedback is used around the circuit so that v_{OUT} is approximately a sinusoidal.

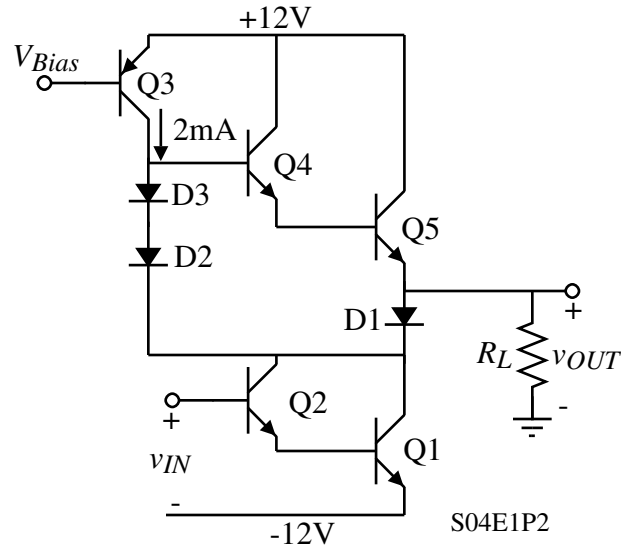

Problem 3 - (25 points)

Find the voltage transfer function of the common-gate amplifier shown. Identify the numerical values of the small-signal voltage gain, v_{out}/v_{in} , and the poles and zeros. Assume that $I_D = 500\mu\text{A}$, $K_N' = 100\mu\text{A}/\text{V}^2$, $V_{TN} = 0.5\text{V}$, and $K_P' = 50\mu\text{A}/\text{V}^2$, $V_{TP} = -0.5\text{V}$, $\lambda \approx 0\text{V}^{-1}$, $C_{gs} = 0.5\text{pF}$ and $C_{gd} = 0.1\text{pF}$.

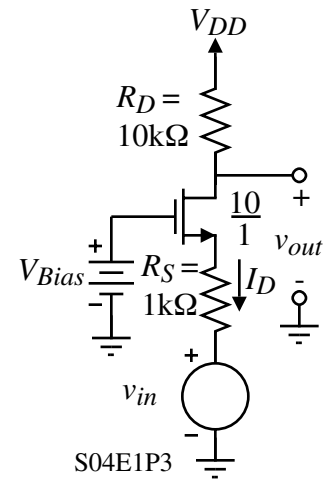

Problem 4 - (25 points)

For the circuit shown, assume all transistors are saturated and that their parasitic capacitors are negligible when compared with the ones shown. Assume that their respective g_m 's and r_{ds} ' are equal.

- Using either the open-circuit or short-circuit time-constant test, determine the 3-dB bandwidth (f_{3-dB}) of the circuit.
- Which capacitor is predominant in determining this frequency?
- Using either the open-circuit or short-circuit time-constant test, determine the location of the highest frequency pole, assuming all the poles are more than an order of magnitude away from each other.
- Which capacitor determines this high-frequency pole?

